

B BETAFENCE



**PROTECTING
THE FUTURE,
TODAY.™**

Betafence Certified Training

OVERVIEW

1. Installation Consideration
2. Post Installation
3. Post to Rail Bracket Installation
4. Rail Installation
5. Mesh and Union Installation
6. Gate Installation
7. Final Securing
8. Touch-Up

BETAFENCE INSTALLATION CONSIDERATIONS



Betafence provides fencing systems that are customized to meet the specific needs of our customer. Each installation is unique as we provide both structurally integrated and aesthetically balanced solutions.

These installation instructions are provided as a **“general guideline.”** Before beginning an installation, please review the approved submittal/installation drawings carefully to ensure proper understanding of the system, as well as any specific engineered requirements before any fence install to make sure you have a complete understanding of each fence project. If drawings do not explain certain specifics of fence erecting, or you have any questions concerning material or installation methods, contact your Betafence field representative, so he or she can address the issue internally to make any changes on the job specifics. If there are any questions about any of the parts or methods concerning installations, contact Betafence at 972-878-7000.

BEFORE INSTALLATION

Before you begin an installation, we recommend that you review your local regulations. Check with appropriate jurisdictions (e.g. state, local, subdivision, etc.) for:

Mandatory Setbacks

Permissible Heights

Style Limitations

Required Permits

Regulations/Codes

Contact all local utility companies to flag all buried cables, pipelines, etc.

Water, gas, phone, electric, cable TV, etc., as well as property owner's buried security cable or anything else that could be underground.

Determine Legal Boundaries of property. Because fence footings must not extend beyond your legally established property line, you will need to know the exact location of that line to be able to mark it prior to installation. If you are uncertain, refer to the real estate plot plan or consult a professional surveyor.

SITE PREPARATION

The initial layout should be free of hazards, obstacles, and debris. Notify Contractor of unsatisfactory conditions. Do not proceed with work until conditions are satisfactory to the installer.

The slope should be considered prior to installation of most security mesh styles. Grading may be necessary to achieve desired results. When possible, it is best to have all slopes to be consistent. If there is slope, and you are not using the SecuriGuard mesh, fence mesh will have to be:

- (1) stepped up or down, or
- (2) cut to match biased grade with mesh following along graded slope (see installation drawings).

PRODUCT HANDLING

Handle fence components carefully to protect finish coating from any scuffs, abrasion or other damage during unloading, storage, and installation. Much time and care goes in to getting the material onsite undamaged.

Some examples of careful handling include wrapping the forks with a protective layer such as plastic or carpet and using wood drayage to set the material on in order to prevent damage to the finish.

HARDWARE

HARDWARE

#14 x 1/2" SQUARE DRIVE PAN HEAD SCREW



#14 x 1" HEX HEAD TEK SCREW



1/2" x 1-3/4" SELF TAPPING BOLT. USED TO SECURE DROP ROOFS AND HEADER BEAMS. (USE 1/8" DRILL BIT FOR PILOT HOLE.)



1/2" x 3" SELF TAPPING BOLT. USED TO SECURE DROP ROOFS AND HEADER BEAMS. (USE 1/8" DRILL BIT FOR PILOT HOLE.)



1/2" BREAKAWAY NUT. USED WITH CARRIAGE BOLTS



1/2" x 2" CARRIAGE BOLT. MOST COMMONLY USED.



1/2" x 3 1/2" CARRIAGE BOLT.



1/2" x 4" CARRIAGE BOLT WITH NYLON LOCK NUTS. USED TO SECURE HINGES TO JAMBS.



1/2" x 3 1/2" ANCHOR BOLT. USED TO SECURE GATE JAMBS (ANCHOR SIZE IS THE SAME AS DRILL BIT SIZE)



OTHER SIZES OF ANCHOR BOLTS USED AS JOB REQUIRES (ANCHOR SIZE IS THE SAME AS DRILL BIT SIZE)



1/2" x 10" ANCHOR BOLT. USED TO SECURE ROLLER GUIDES FOR OVERHEAD SLIDE GATE. (ANCHOR SIZE IS THE SAME AS DRILL BIT SIZE)



HIGH SECURITY APPLICATION: TENSION BAND BRACKET



HIGH SECURITY APPLICATION: TYPE 4 SHEET TO RAIL COR. USED TO SECURE MESH TO RAIL.

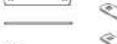

HIGH SECURITY APPLICATION: UNION RETENTION STRAP. USED TO SECURE MESH TO HIGH SECURITY GUARDIAN UNION.



HIGH SECURITY APPLICATION: TERMINAL UNION RETENTION STRAP. USED TO SECURE TERMINAL HIGH SECURITY UNION TO MESH.



HIGH SECURITY APPLICATION: INSIDE CORNER L-BRACKET. USED TO SECURE INSIDE CORNER HIGH SECURITY UNIONS.



1" x 4" WEAR SLEEVE. USED ALONG WITH SLIDING GATE DROP ROD



2" SQUARE PLASTIC PLUG USED TO PLUG ENDS OF SQUARE RAILS



1-1/2" ROUND PLASTIC PLUG USED TO PLUG ENDS OF ROUND RAILS



HIGH SECURITY APPLICATION: ROUND POST HIGH SECURITY RAIL HANGER. USED TO SECURE RAIL TO POST



HIGH SECURITY APPLICATION: SQUARE POST HIGH SECURITY RAIL HANGER. USED TO SECURE RAIL TO POST

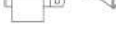

HIGH SECURITY APPLICATION: END CLAMPS. USED TO SECURE INSIDE CORNER RAIL TO RAIL.



GATE AND DOOR TRIM



OUTSIDE CORNER TRIM



HIGH SECURITY APPLICATION: HIGH SECURITY GUARDIAN UNION. USED TO ATTACH MESH TO RAILS ALONG EDGES OF MESH



SQUARE AND ROUND POST CAPS.



NOTE: PLACE CARRIAGE BOLT WITH HEAD FACING RAIL AS SHOWN BELOW.

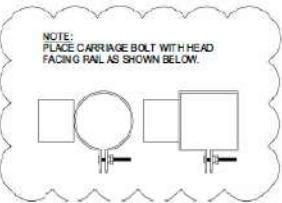

RECOMMENDED TOOLS FOR INSTALLATION

- EXTENSION CORDS
- NUT DRIVER CHUCKS
- DRILLS / SCREW GUNS
- LADDERS
- RUBBER MALLET
- WRENCHES
- SOCKET SET
- BAND, RECIPROCATING, CUT-OFF SAW AND/OR GAS POWERED CUTTER
- LEVELS
- STRING LINES
- MARKERS
- CONCRETE DRILL BITS
- STANDARD DRILL BITS
- VARIABLE REACH FORKLIFT AND / OR SCISSOR LIFT DEPENDING ON TYPE OF TERRAIN & FENCE HEIGHT
- CIRCULAR SAW DEPENDING ON TYPE OF MESH
- BOLT CUTTERS

HARDWARE		SALES ORDER: XXXX	CUST. PART #:
PROJECT NAME:	XXXX	XXXX	XXXX
SUB TO MEN:	XXXX	XXXX	XXXX
VIEW:	MULTI		
SCALE:	NFD		
DRAWN BY:	KAM/SMK		
CHECKED BY:	XXXXXXXXXX		
DATE:	01 AUG 08		
FILE:	HIGH SECURITY		
REV:	DATE:	DRAWN BY:	CHECKED BY:
SHEET			
3.00			

POST INSTALLATION

Space posts at dimensions indicated in the approved installation drawings within design maximum tolerances. Post spacing will vary from one project to another.

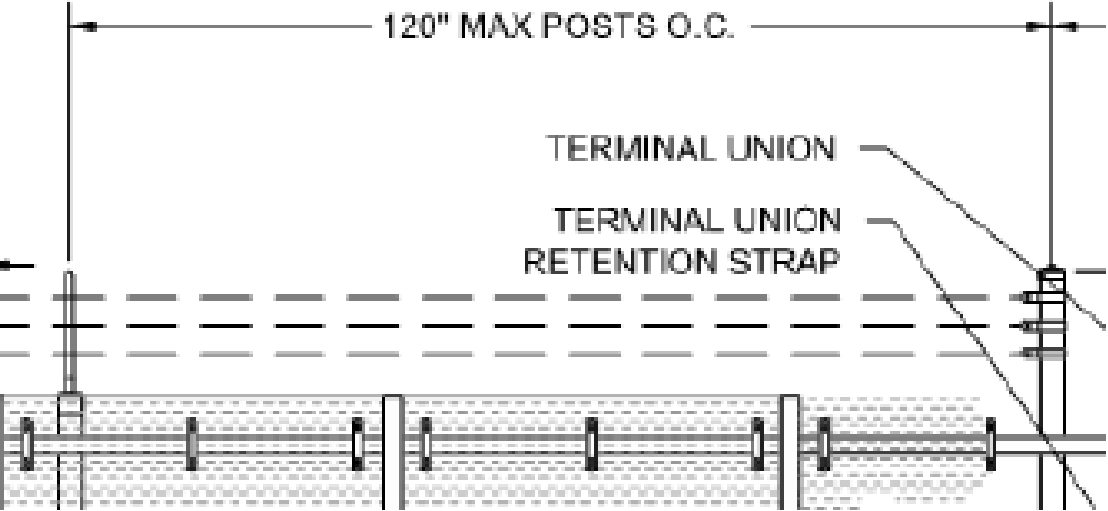

POST INSTALLATION

Maximum post spacing is critical to meet engineered wind loads, and to ensure proper gate openings. Post spacing is not critical for the fence itself, allowing for easier and faster installation. There is generally a "+2" tolerance on the post spacing. Your specific post spacing will be called out on your specific Betafence Site Drawings. Post spacing can vary from project to project as well as within a project. Know your required spacing limits prior to digging. Dig post holes at designated points, using pre-approved method(s) of digging. Pay particular attention to post and pier type, as your project may have multiple post types and ground conditions along any given fence run to accommodate for a multitude of things, including but not limited to soil bearing capacity, cameras, grounding, lights, gates, etc. There are a multitude of methods of digging. This is critical to know in advance in order to develop your install plan. Other things to consider: 1) Are you installing an anti-dig barrier? 2) Are you in a utility substation, requiring grounding?



POST INSTALLATION

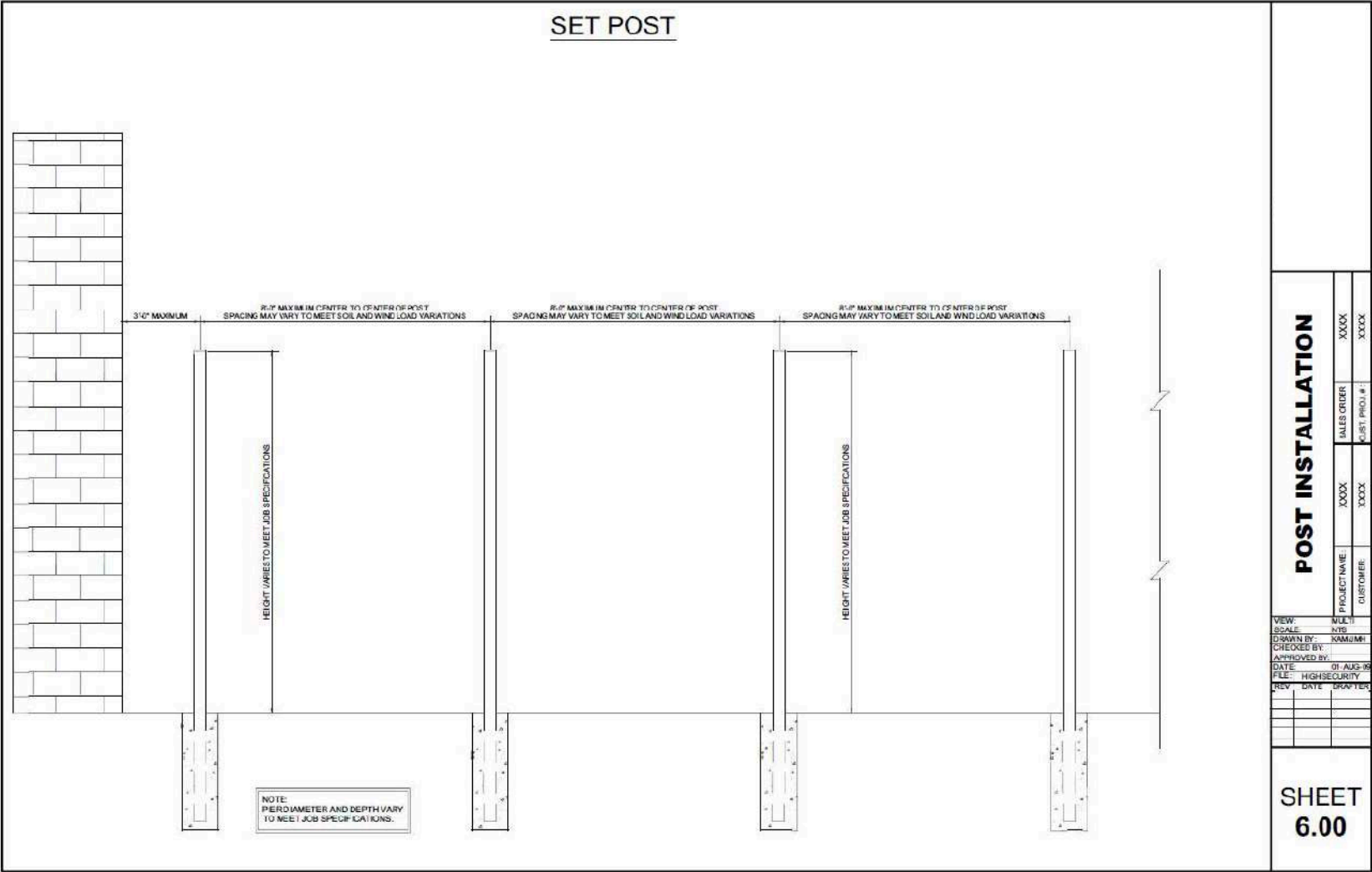

POST INSTALLATION

The depth and diameter of the hole may vary depending on local wind load requirements and soil conditions. Regardless of the depth of the hole, post height (from the ground line) should match as indicated on the installation drawings. Center posts in holes for maximum wind load stability.

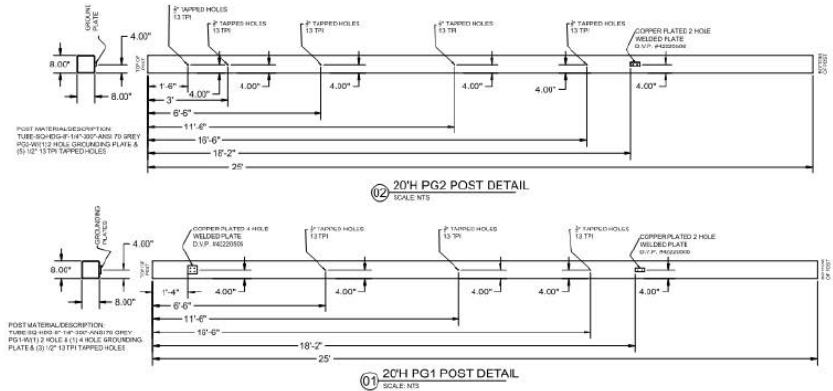

LINE POST
P/N: 56395
20'H FENCE - PG2
COLOR: ANSI 70 GREY
PIER: 36"DIA. x 6'-6"DEEP

SLIDE GATE LINE POST
P/N: 56396
(2ND SPAN OUTER SLIDE GA)
20'H FENCE - PG1
COLOR: ANSI 70 GREY
PIER: 36"DIA. x 6'-6"DEEP



POST INSTALLATION

Place rebar, if required, in each hole before concrete pour.
Surround each post with concrete in a continuous pour.
Trowel finish around posts, sloping downward to direct water away.
Before the concrete sets, double check that the posts are set plumb, aligned, at correct height and spacing as determined by approved installation drawings.

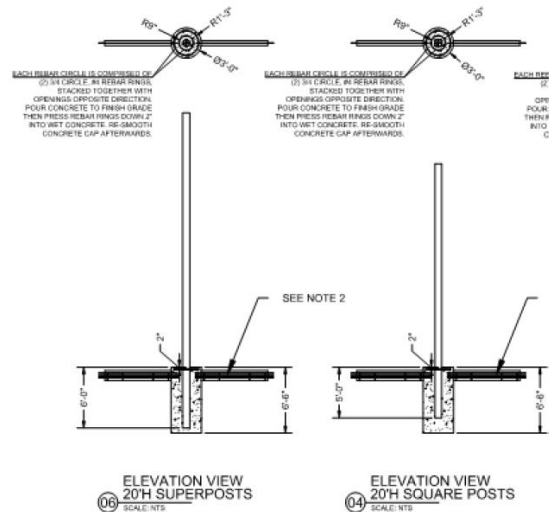

POST INSTALLATION

Posts may need to be stabilized in position during placement and finishing operations until concrete is sufficiently cured. Please refer to concrete instructions to determine the cure time.



POST INSTALLATION

Posts may need to be stabilized in position during placement and finishing operations until concrete is sufficiently cured. Please refer to concrete instructions to determine the cure time.



POST INSTALLATION

Ideally, once posts are set and piers are sufficiently cured to allow for mesh installation, bring all ground to finish grade per project specifications. This will allow the mesh to rest at grade, unless otherwise specified, while installing.



RAIL HANGER INSTALLATION

The Betafence system uses our patented EZ-Up style. This is to allow for a more labor efficient installation. Only use brackets specified for this project, as detailed on approved installation drawings. Pay special attention to the different bracket types (i.e., terminals, inside and outside corners, etc.). Field welding of any kind is generally not needed. The Betafence system is designed for minimal or no field welding. If welding is required, follow paint and galvanizing touch up procedures per drawings to minimize damage to the galvanizing and/or powder coat protective finishes.

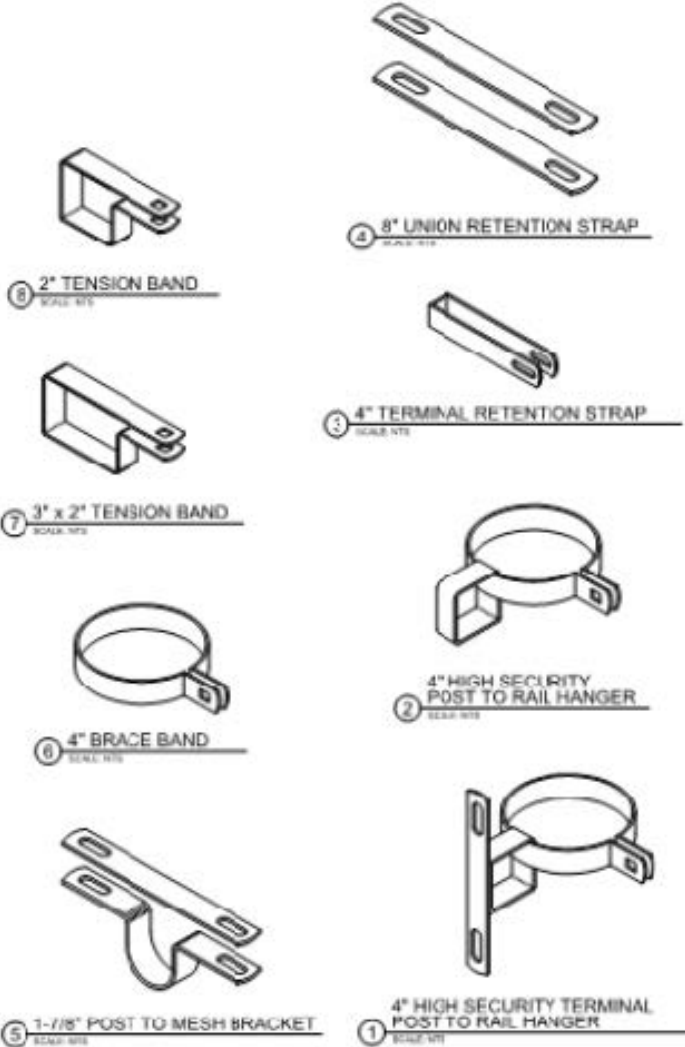

RAIL HANGER INSTALLATION

Using provided jig, designed specifically for this installation, or measurements from installation drawings, install rail hangers using hardware provided at the correct height specified in approved installation drawings.

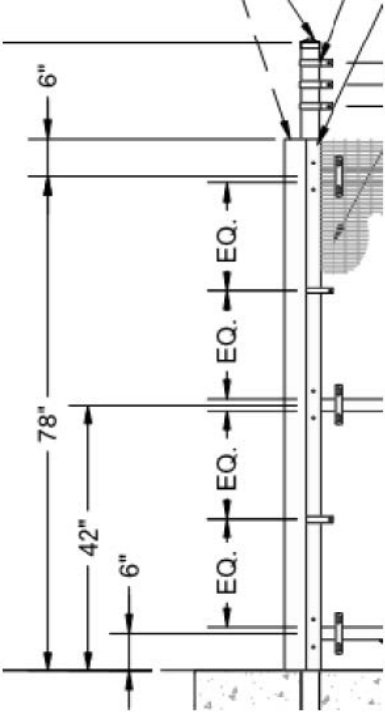
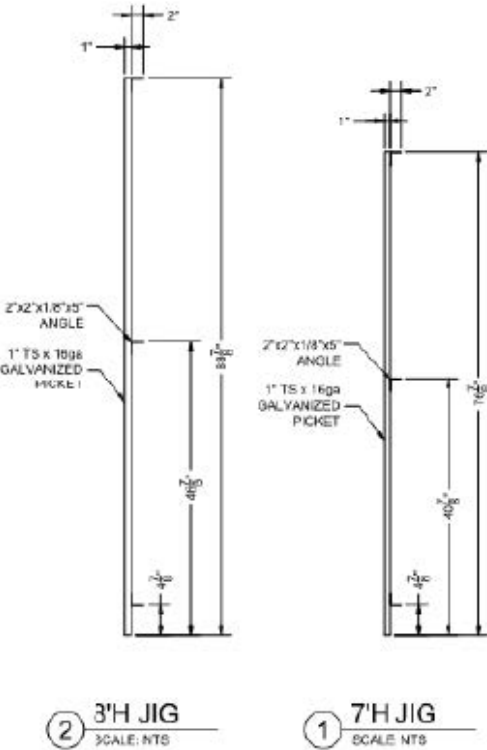

RAIL HANGER INSTALLATION

All the Post to Rail brackets should to be slid down from the top of the post. Installing these brackets by opening them up to wrap around the post is an inappropriate installation method which may void the warranty for these brackets, if the finish is damaged by th is process. Use a drill with a clutch or hand wrench. Do not break the nut. Tighten the breakaway nut just snug enough to prohibit the bracket from moving. This will allow for adjustment of bracket if necessary after completion of rail installation. Refer to approved installation drawings for correct orientation of rail hangers (off-set of band). Continue this process until all rail hangers are installed.



RAIL HANGER INSTALLATION

Starting with the non-swaged end to minimize waste, insert the rails through the rail hanger brackets. This allows the use of the swaged end if needed somewhere else, when the rail is cut to fit at the end of the fence run. At gate openings, center the jambs, if applicable, in the gate opening at the specified measurement per approved drawings. Cut the rails to fit, and anchor the jambs to the pier, or set in concrete (see installation drawings). Once the rails are installed, the brackets can be adjusted up or down to give the rails a smooth continuous look, allowing for minor deviations. Do not worry about the looseness of the rail in the bracket. This is normal and will fit snug once mesh and brackets are installed and tightened. **Please Note: Betafence 5000/7000 is designed with the rail to be used as a continuous conduit. Never penetrate the rails with screws or bolts, unless specifically called out on the installation drawings.**



RAIL INSTALLATION

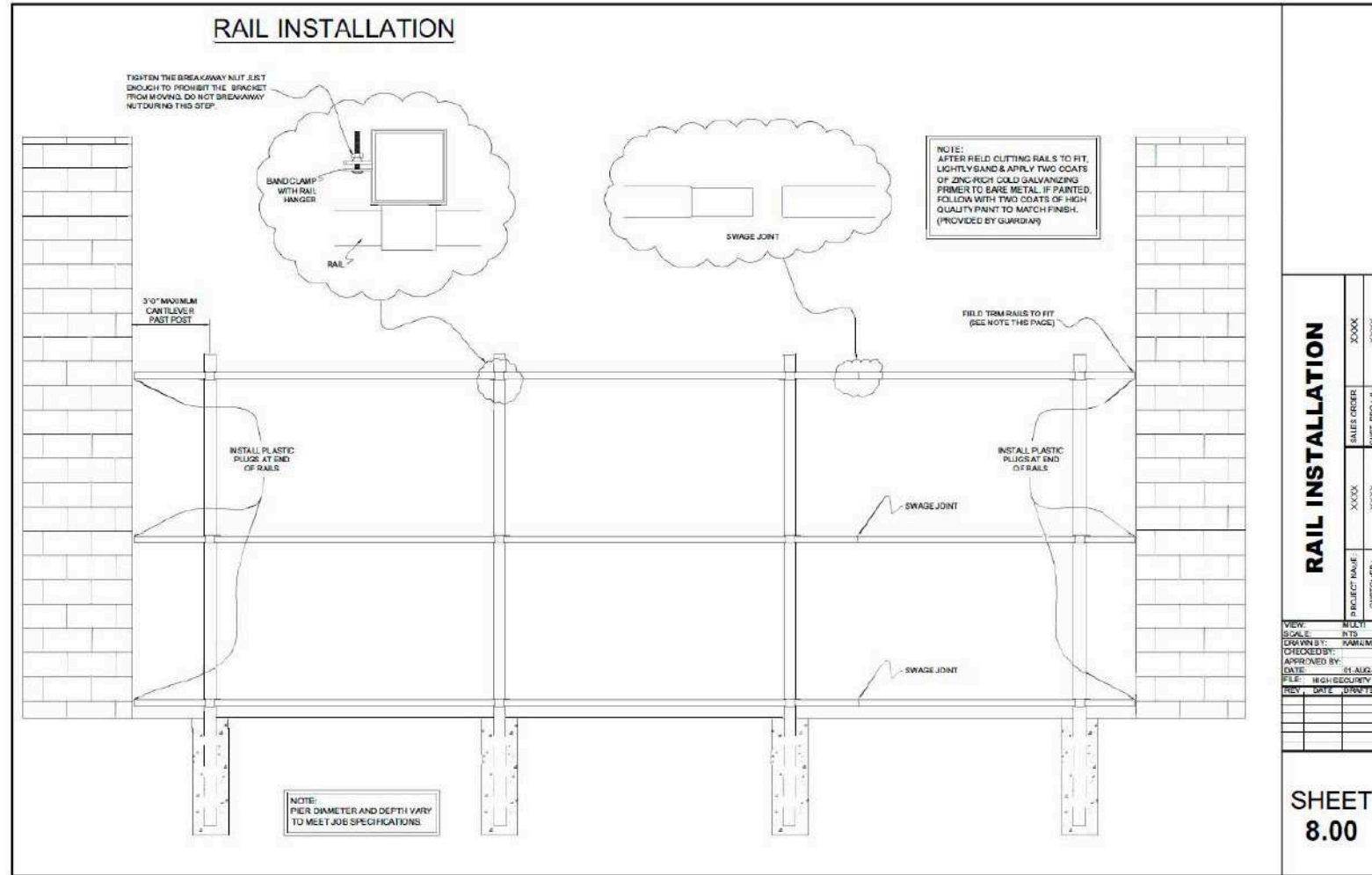

MESH INSTALLATION

Avoid unnecessary cutting, drilling and welding of pre-finished fence mesh panels and components to protect product warranty. If necessary to cut, drill or weld, or otherwise modify product due to field conditions, please repair factory finish in accordance with Guardiar supplied touch-up paint and/or cold galv. as needed in accordance with touch-up instructions in section 8 below. Field fitting hardware may be necessary at corners less than 90 degrees and more than 70 degrees. With post to rail brackets and rails correctly installed, place the union in the correct position, depending on your starting point (i.e., outside corner, inside corner, gate.)

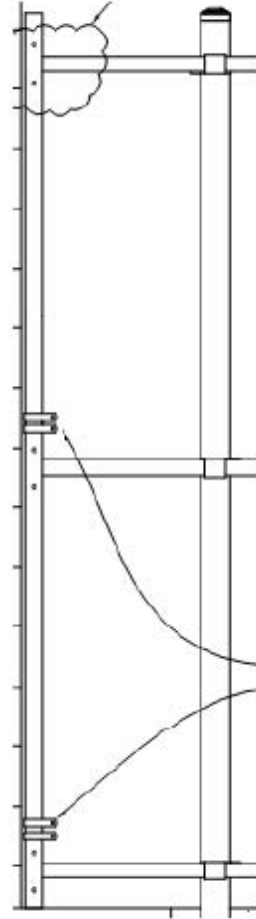

MESH INSTALLATION

Note: all trim pieces are designed to attach under the union with the bolt also going through the trim. Do not place the trim in the union channel because this will allow an easy breach point (see detail on installation drawings).

Use correct brackets and hardware for the particular starting point as shown in installation drawings. Make sure terminal union retention straps are placed on the terminal union before securing the trim under the union. Once the union is in place, snug it to the terminal post to rail brackets to secure union but do not break nut, then begin installing the mesh.

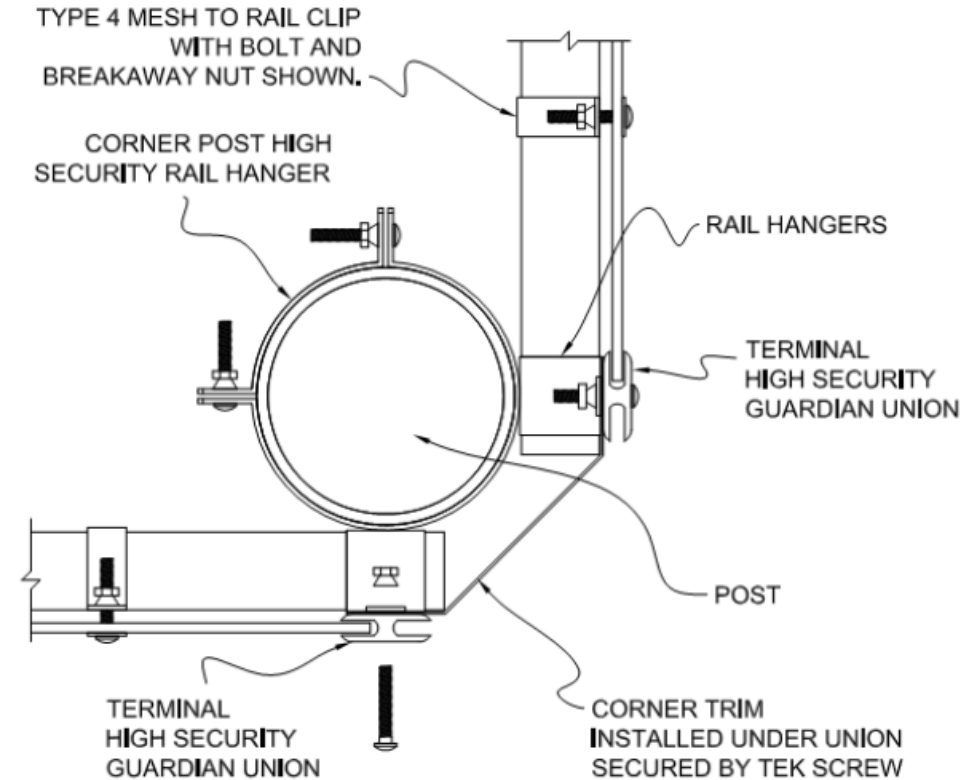

MESH INSTALLATION

Depending on the mesh type, pay particular attention to the mesh orientation. Install the mesh to match the orientation on the gates or, if no gates were provided, look at the installation drawings. Make sure all mesh panels are installed facing the same way, since there is a real top and bottom and you will notice the sheen difference if installed incorrectly. Proper installation of mesh is done by sliding the mesh into the union channel.

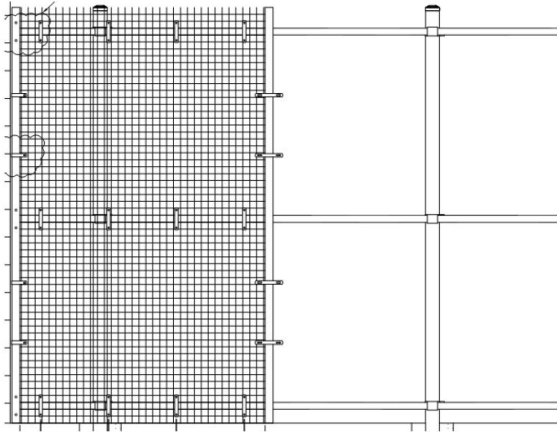

MESH INSTALLATION

Using the correct mesh to rail bracket and hardware provided, attach enough brackets to the mesh to hold secure. For expediency, use only enough to secure the mesh. Additional brackets and hardware can be applied after the panels are installed. Slide your next union onto that panel of mesh, followed by the next panel of mesh, again attaching enough brackets to hold mesh in place. Continue until you have reached the end of that fence run.



MESH INSTALLATION

For areas of grade change, either step the mesh up or down, Or cut the mesh to follow the slope, depending on the severity of the slope, and customer preference. SecuriGuard mesh racks, conforming to grade change, so cutting may not be necessary for installation of these panels, except at terminations.

Two or three panels from the end of the fence line, measure the remaining distance. If you are going to be left with less than a full mesh width at the end of any run, the fence mesh can be cut to fit. Refer to approved installation drawings for details. If the last panel of mesh needed is very small, Cut the last two or three panels to obtain a more balanced look.



MESH INSTALLATION

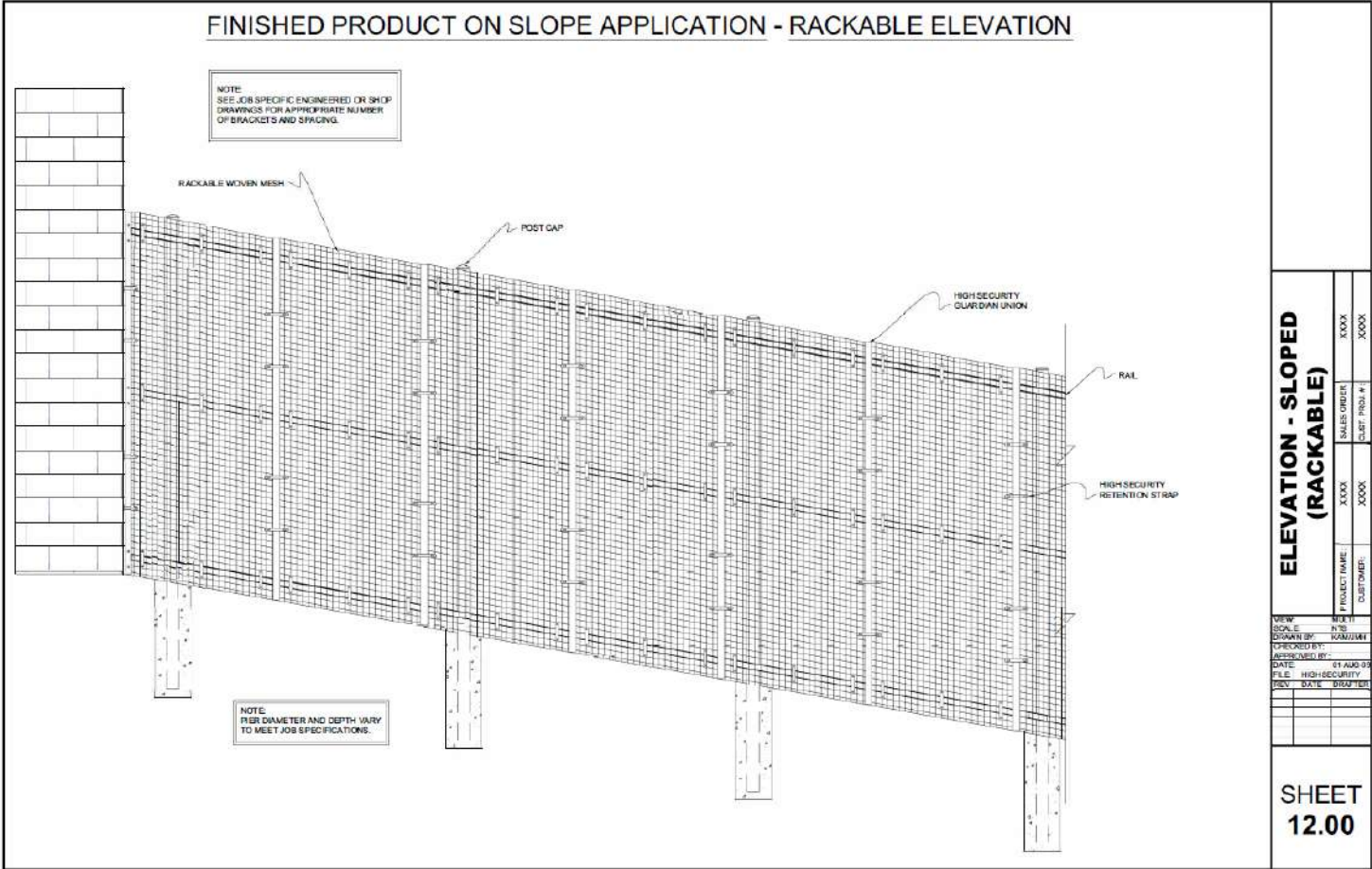

MESH INSTALLATION

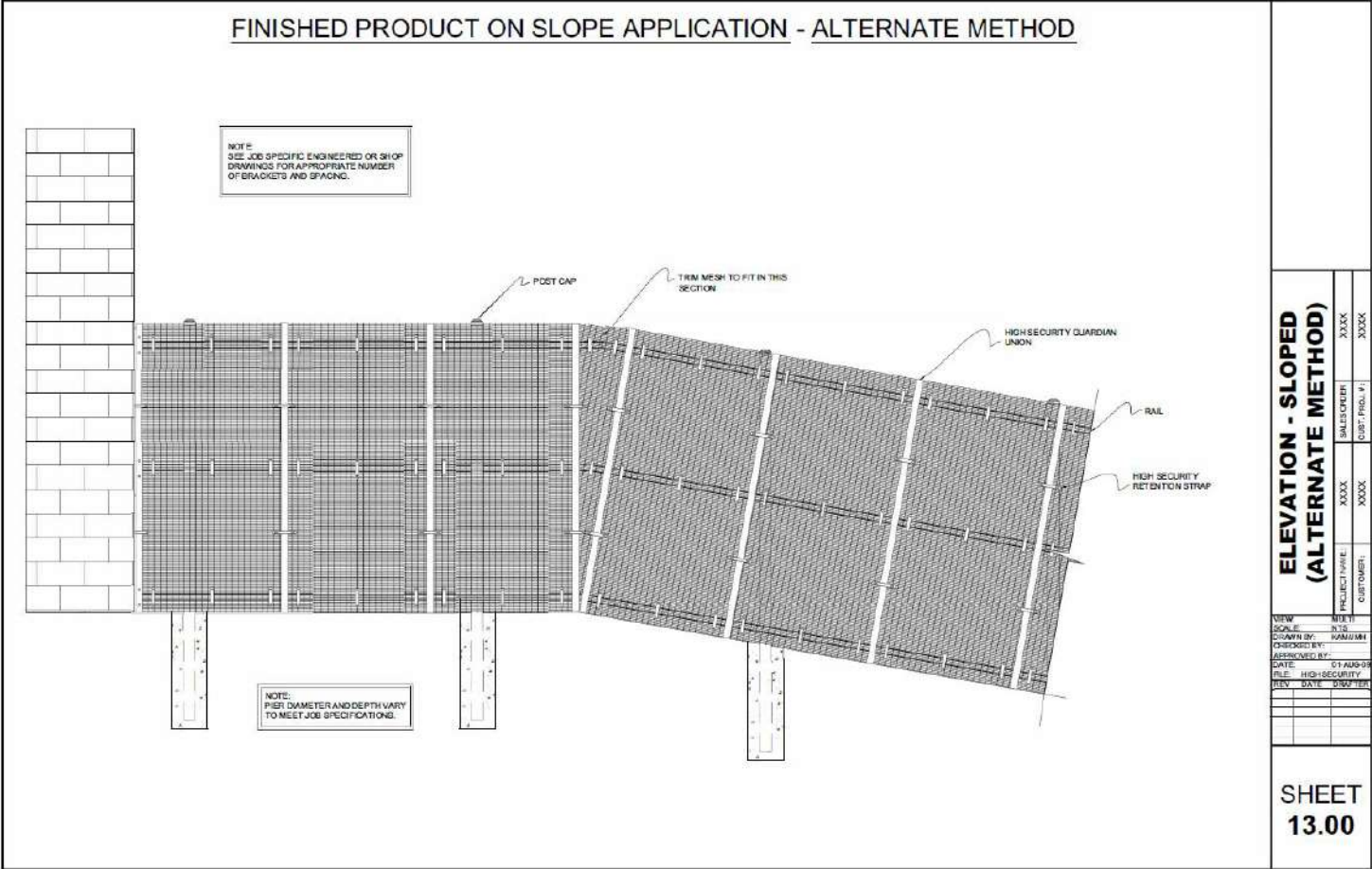

MESH INSTALLATION

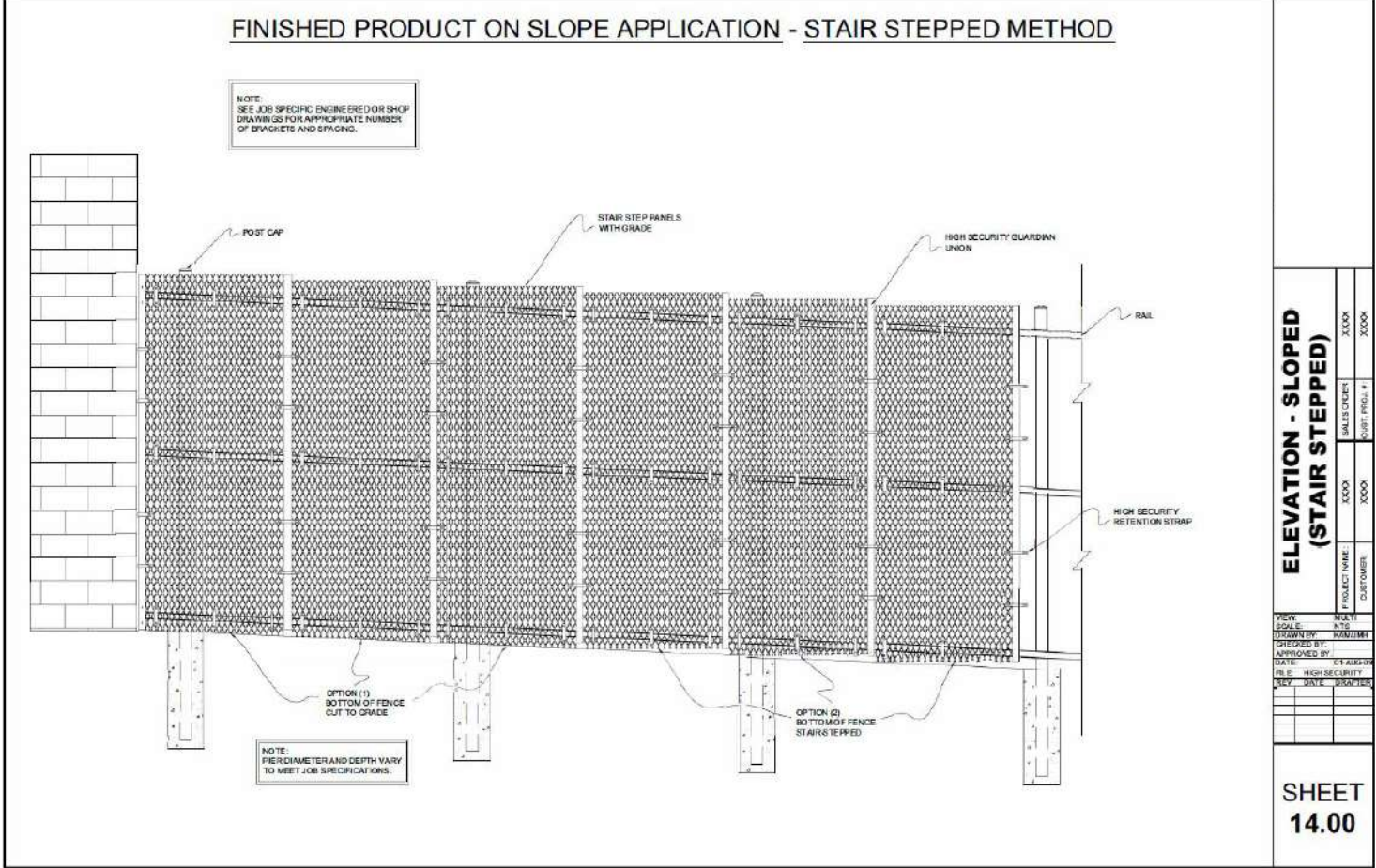

GATE INSTALLATION

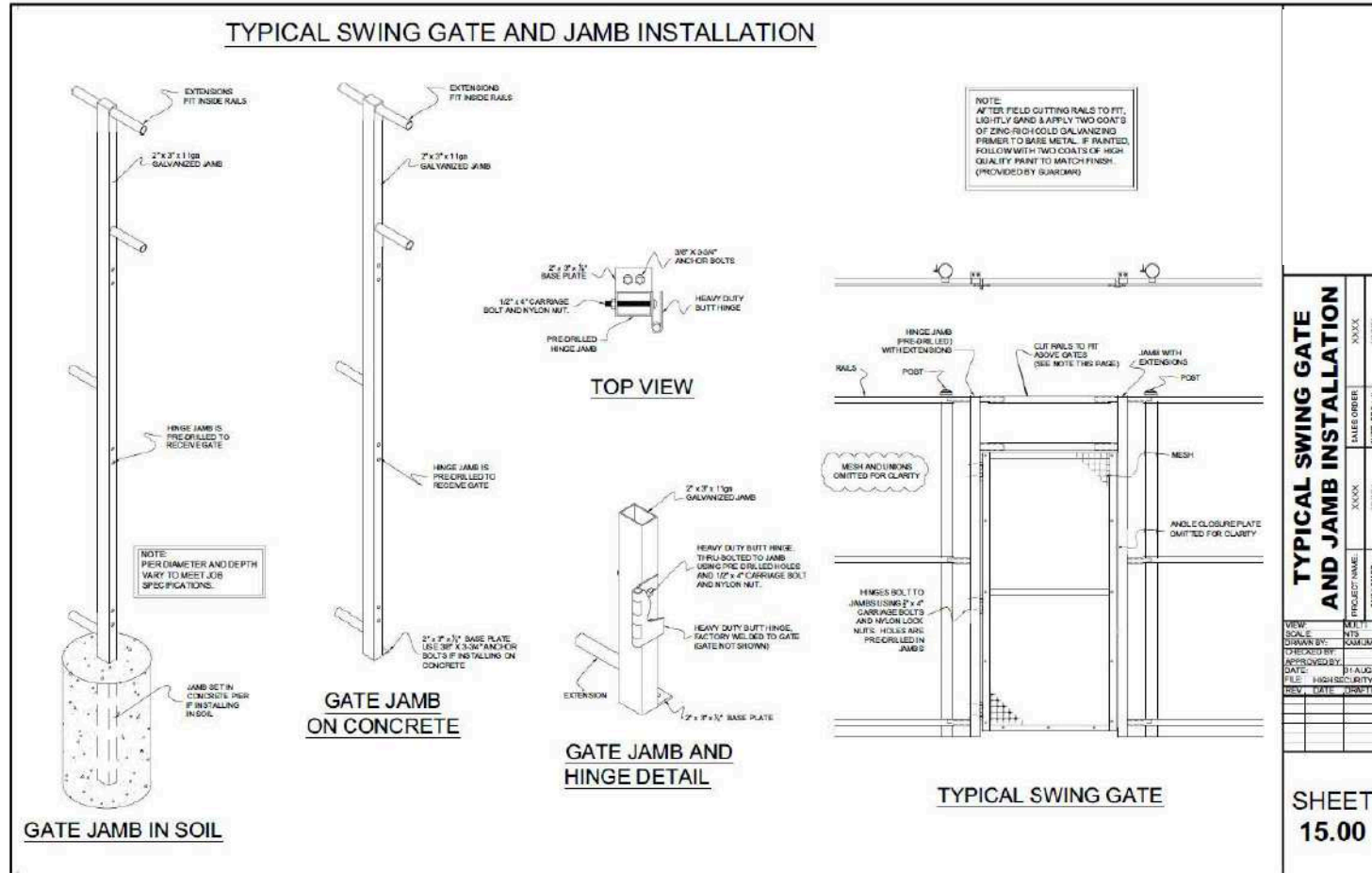

GATE INSTALLATION

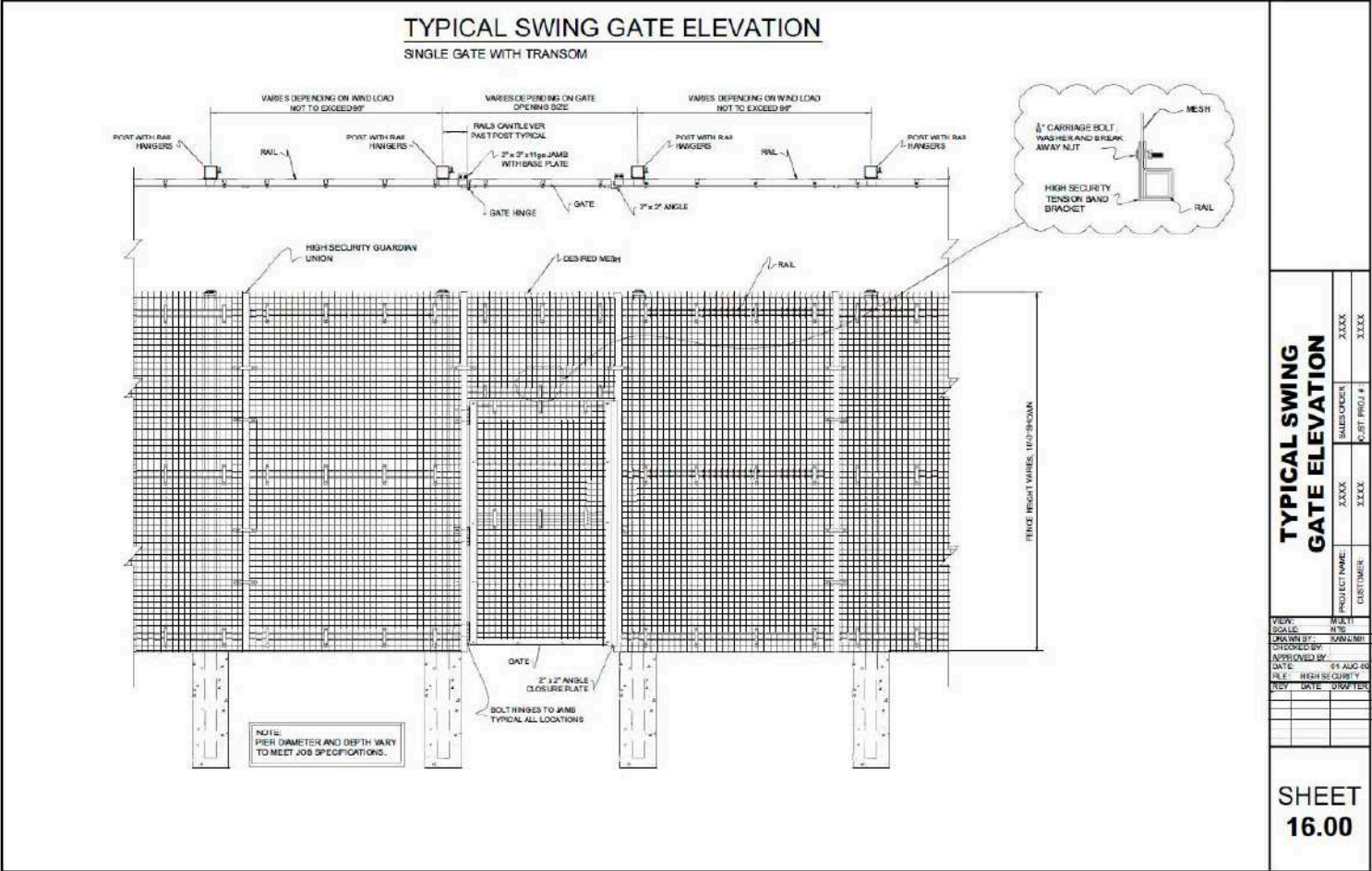

GATE INSTALLATION

For gates without jambs, pay particular attention to the post placement detail. These posts are usually offset to have the rail terminate into the post and welding. The gate leaf will generally have the hinges factory welded to the frame, requiring field welding to the gate post.

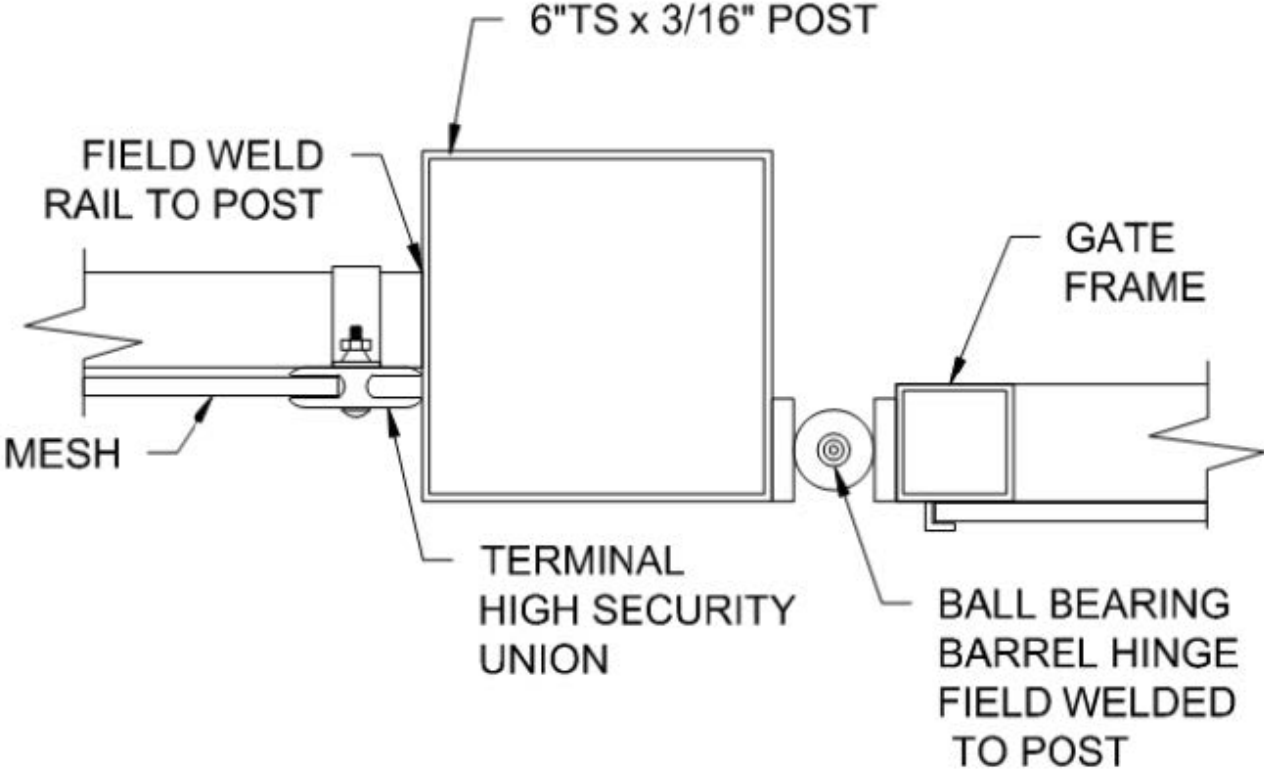

GATE INSTALLATION

Overhead (OH) Slide Gates - Prior to mounting the gate, study both the approved and installation drawings carefully to become familiar with the installation process. Determine header beam height for the OH gate from the approved drawings. Measure and cut the header beam to fit. Place the header beam at the correct height and weld or mark the post to determine where to drill, based on approved drawings. Using drill bit specified, pre-drill the holes. Position the header beam in place and secure using through bolts. Once secure, put a TEK screw into the top and the back of the header beam to join it to the sleeve, if the header is a two piece. Next, using spacers provided (if required), attach the track per detail on the drawings using dowels to attach track segments together. Next attach transom per detail using hardware provided. Depending on the size of gate, it could be 1 panel or multiple panels. If it is shipped in multiple panels, determine which ones are the first, the middle, and last piece, most cases panels will be universal. Starting with the first section, or if the gate is shipped complete, install the truck(s) per installation drawings. Next, position the gate or section at the end of the track. Insert the truck(s) into the track and slide the gate or section into position. For multiple section gates, repeat the process for the middle and end sections. For the multiple section gates, connect the sections, using the bolts, nuts, and washers provided per installation drawings. Install drop rods, gate catch if applicable, on gate, gate stops, and emergency stop bolts in track. See installation drawings for details. Single slide gates may have additional headers that are placed between terminal post and line post to stiffen track. Angle iron may be attached to top and bottom of larger overhead slide gates to stiffen gate. Refer to installation drawings. Both termination posts at overhead slide gates will have a finished trim kit that is placed to hide rail ends for a nice finished look, and terminal unions with predrilled holes are placed on top with terminal union retention straps to maximize security. All exposed post to rail bracket bands must be welded to the posts.

GATE INSTALLATION

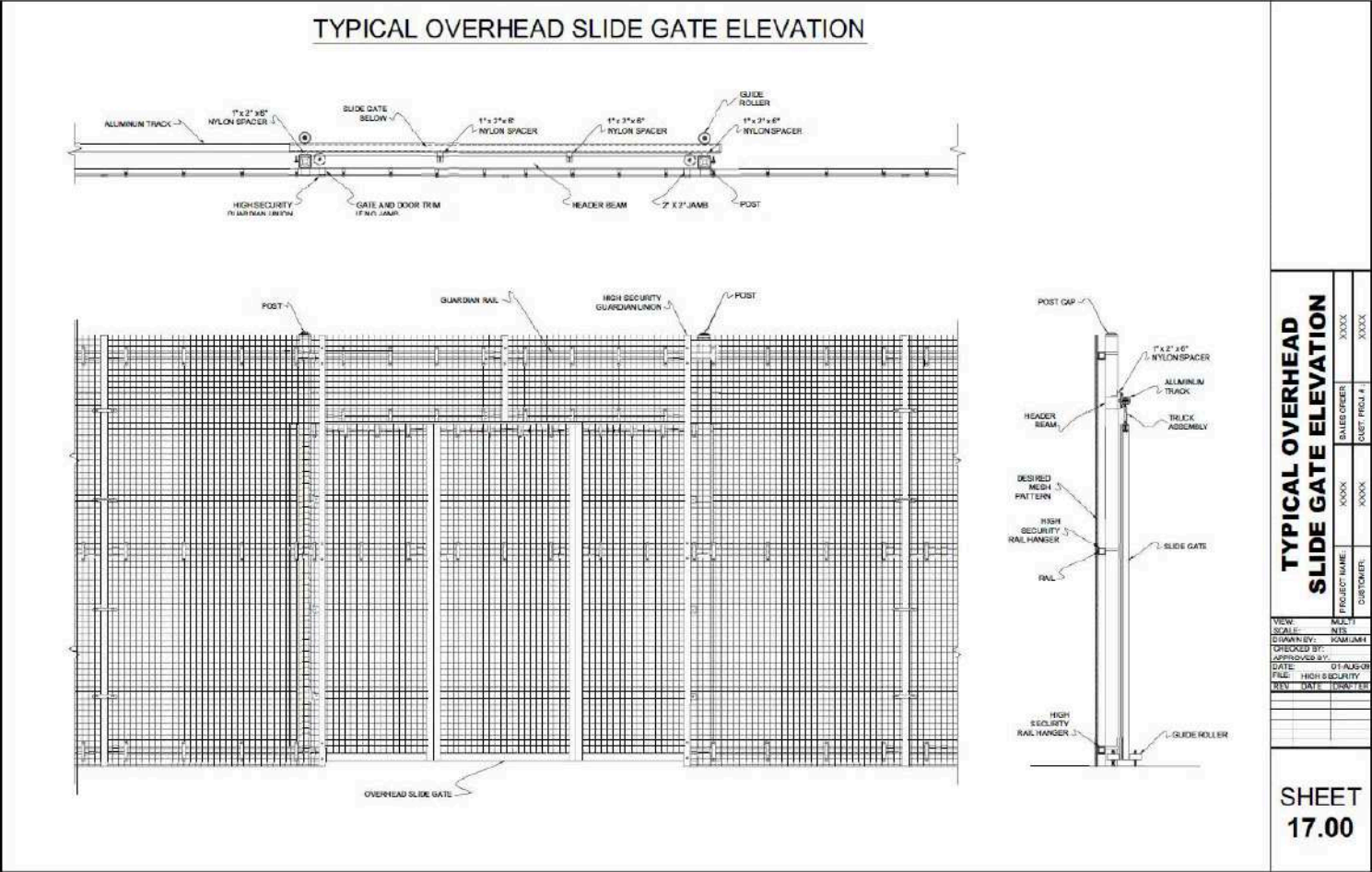

GATE INSTALLATION

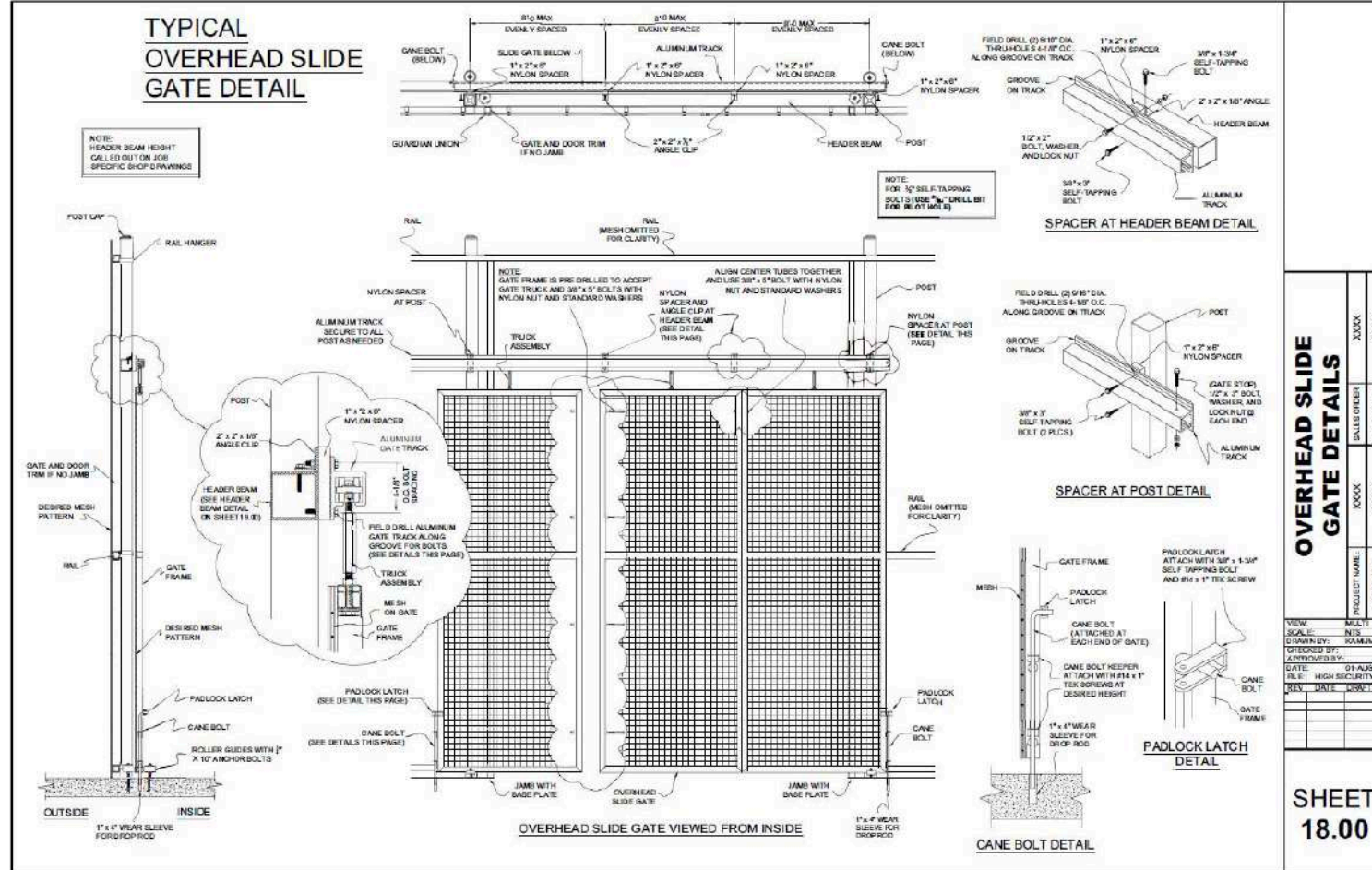

OVERHEAD SLIDE GATE DETAILS

VIEW	MULTI	SALES ORDER	XXXX	XXXX
SCALE	NIS	PROJECT NAME	XXXX	XXXX
DRAWN BY	XXXXXXXX	CUSTOMER	XXXX	XXXX
CHECKED BY				
DATE	01-AUG-09			
REV	DATE	DESCRIPTION		

SHEET 18.00

GATE INSTALLATION

Cantilever Gates - Cantilever gates generally come as a complete gate with the track already mounted, depending on shipability. Using approved drawings and the cantilever gate installation instructional drawings, install truck brackets and trucks to posts at specified height. Lifting the gate in place, slide the gate track onto the trucks. Install the gates stop(s) and emergency stop bolts in the track. Install drop rods and gate catch if applicable.

GATE INSTALLATION

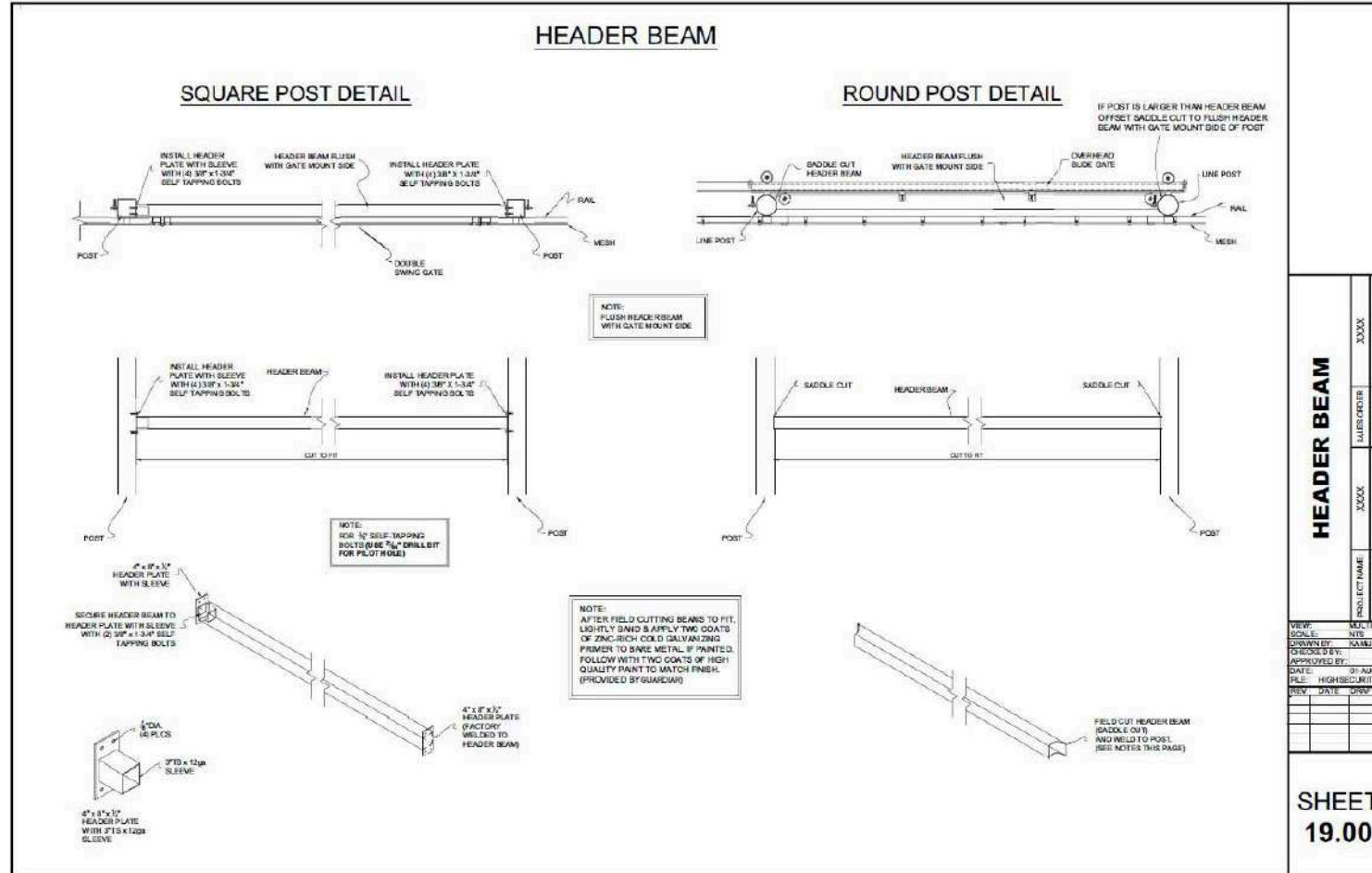

GATE INSTALLATION

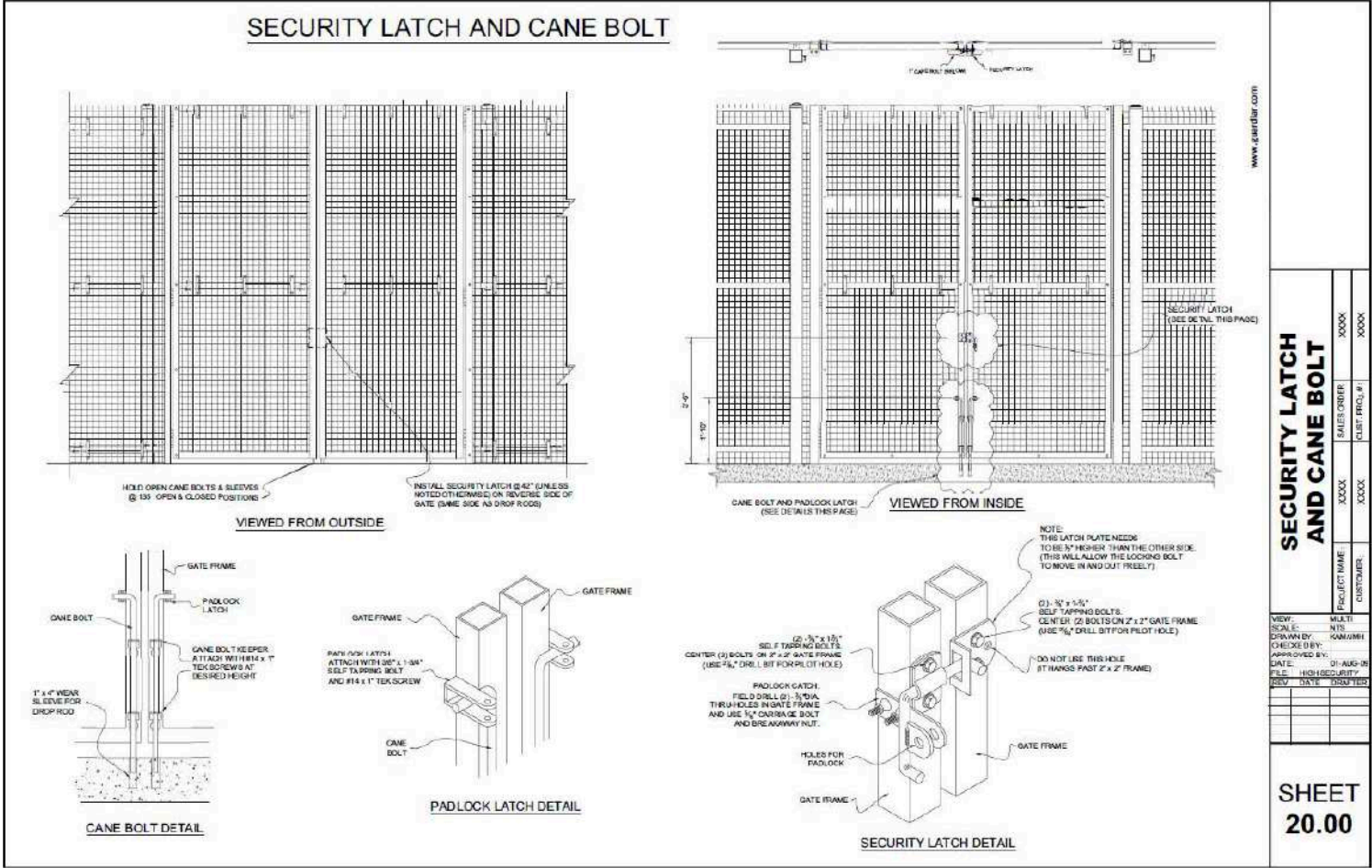

SECURITY LATCH AND CANE BOLT

SALES ORDER	XXXX
CLIENT PROJ. #	XXXX
PROJECT NAME	XXXX
CUSTOMER	XXXX

VIEW:	MULTI
SCALE:	N/A
DRAWN BY:	KAMUMI
APPROVED BY:	
DATE:	01-AUG-18
FILE:	HIGH SECURITY
REV:	DATE

SHEET 20.00

FINAL SECURING

Once the mesh installation is well under way, the final securing may begin. Attach all remaining brackets and hardware. All nuts should be securely fastened with a constant drill speed until breakaway nuts break. Remove and discard that portion of the nut.



FINAL SECURING

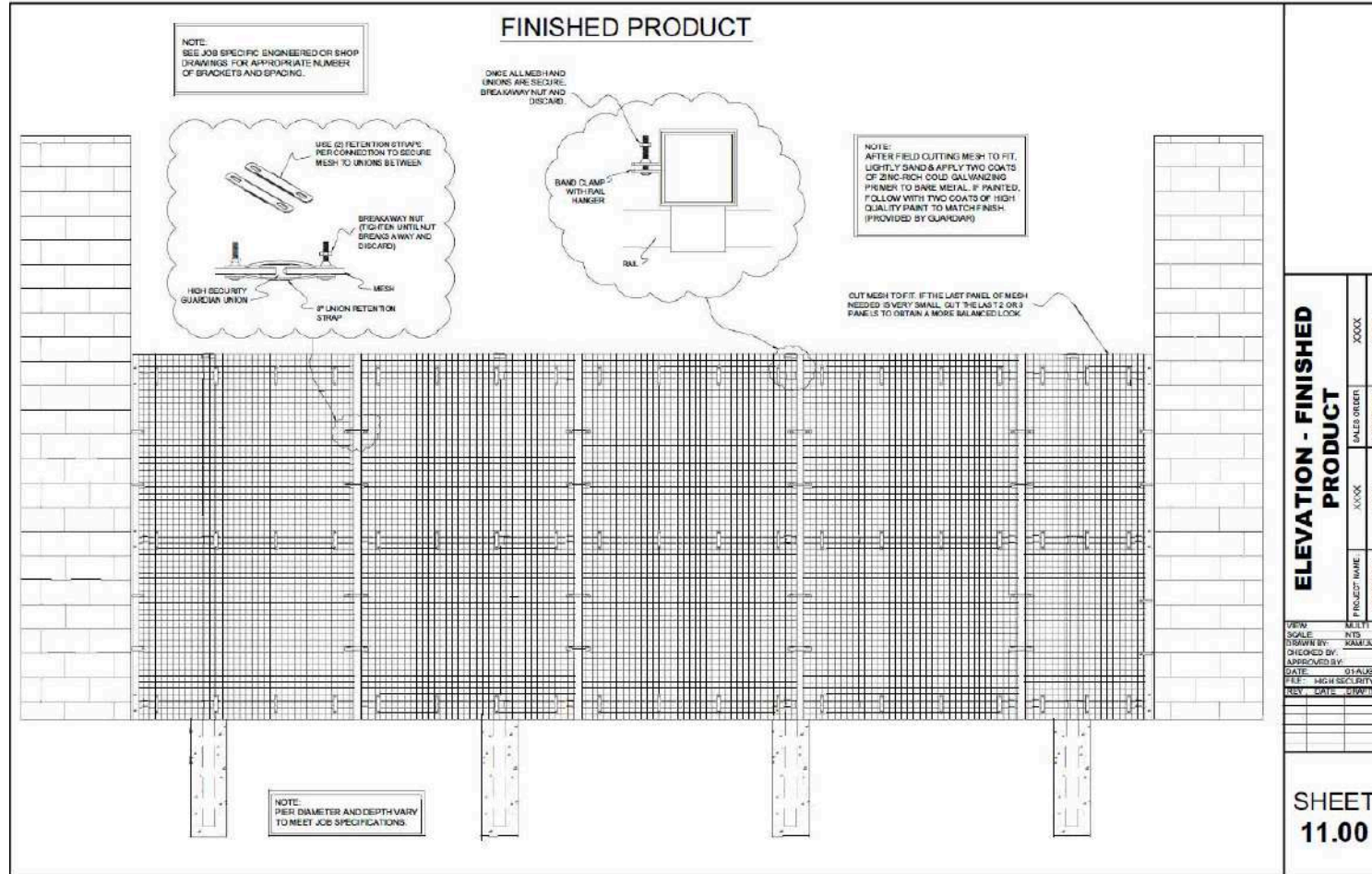

ELEVATION - FINISHED PRODUCT

PROJECT NAME:	XXXX
CUSTOMER:	XXXX
SALES ORDER:	XXXX
CUSTOMER #:	XXXX

VIEW: MULTI
 SCALE: NTS
 DRAWN BY: ZAMEKAT
 CHECKED BY:
 APPROVED BY:
 DATE: 01 AUG 08
 FILE: HIGH SECURITY
 REV: DATE: DESCRIPTION

SHEET 11.00

TOUCH-UP

Touch-up necessary areas by lightly sanding, then apply two coats of zinc-rich cold galvanizing primer, 93% or higher zinc, (typically provided by Betafence) followed by two coats of high quality acrylic lacquer paint (may or may not be provided by Betafence) to match finish. Testing for final color match should always be performed and allowed sufficient dry time prior to full implementation of project touch up. All touch up should be stored in a temperature controlled environment. Follow all manufacturer storage and application recommendations. For aerosol application, apply with a dauber or brush when necessary to prevent overspray and minimize total area covered. Note: field applied touch-up cannot match the performance of factory applied finishes and should be limited in use.



FIELD SUPPORT CONTACT INFORMATION

Doug Winters

Product Support Specialist

214-546-0611 Cell

doug.winters@praesidiad.com

IB BETAFENCE

THANK YOU

Betafence is part of Praesidiad, a global leader in perimeter security solutions. Other brands owned by Praesidiad include Hesco, also a market leader in their field.

info@betafence.com
www.betafence.com

 **BETAFENCE**
a PRÆSIDIAD brand